

# KT-502H Series

## Temperature Transmitters with HART Protocol

### ■ Features

- HART protocol
- Display rotation in 330 ° range
- Better visibility with supporting backlight function
- Various inputs (to order, select one from 22 kinds)
  - RTD 8 types
  - Thermocouple 8 types
  - mV 8 types
  - Resistor 2 types
- Explosion-proof specification: Ex D IIC T6
- Protection structure: IP67 (IEC standard)



**!** Please read "Safety Considerations" in the instruction manual before using.



### ■ Ordering Information

|    |   |      |   |                                 |
|----|---|------|---|---------------------------------|
| KT | — | 502H | 0 | (-270 to 1372, K) <sup>※1</sup> |
|    |   |      | ① | ②                               |

| Item                     | Description   |                 |   |              |
|--------------------------|---|-----------------|---|--------------|
| ① Mounting bracket       | 0   | Without bracket | 1 | With bracket |
| ② User temperature range | ※ 1: To order this unit, write the temperature sensor type and the temperature range. |                 |   |              |

### ■ Specifications

|                               |  |  |  |
|-------------------------------|--|--|--|
| Model                         | KT-502H  |  |  |
| Power supply                  | 10.5-45VDC $\overline{=}$ (with backlight LCD)   |  |  |
| Display method                | PV display part: 7-segment 5-digit (character size: W4×H8mm),<br>Parameter display part: 14-segment 8-digit (character size: W2.6×H4.8mm),<br>52-bar meter |  |  |
| Display range                 | -19999 to 99999  |  |  |
| Setting method                | HART-protocol (no setting key)   |  |  |
| Response time                 | 1 sec  |  |  |
| Input type                    | RTD  | DPT100Ω, DPT500Ω, DPT1000Ω, Ni100Ω, Ni500Ω, Ni1000Ω, Cu50Ω, Cu100Ω |  |
|                               | Thermocouple   | K, J, T, E, N, S, B, R   |  |
|                               | Resistance transmission (Ω)  | 0 - 400Ω, 0 - 2000Ω  |  |
|                               | Voltage transmission (mV)  | - 10 - 75mV, - 100 - 100mV, - 100 - 500mV, - 100 - 2000mV          |  |
| Output                        | DC4-20mA (2-wire)  |  |  |
| Accuracy                      | ±0.3%  |  |  |
| Alarm                         | Below 3.8mA, Over 20.5mA/Sensor break 3.6mA  |  |  |
| Load                          | Max.(V power supply - 7.5V)/0.22A  |  |  |
| Galvanic insulation           | 2,000VAC (input/output)  |  |  |
| Environment                   | Ambient temperature  | -20 to 70°C, storage: 20 to 80°C                                   |  |
|                               | Ambient humidity   | 0 to 85%RH, storage: 0 to 85%RH                                    |  |
| Explosion class <sup>※1</sup> | Ex d IIC T6  |  |  |
| Protection structure          | IP67 (IEC standard)  |  |  |
| Material                      | Body: Aluminum (AlDc.8S), Cover O-Ring: Buna N   |  |  |
| Weight <sup>※2</sup>          | Approx. 1.4kg (approx. 1.2kg)  |  |  |

※1: The explosion class specification is acquired and managed by KONICS.

※2: The weight includes packaging. The weight in parenthesis is for unit only.

※Environment resistance is rated at no freezing or condensation.

# Temperature Transmitters with HART Protocol

## ■ Dimensions

(unit: mm)

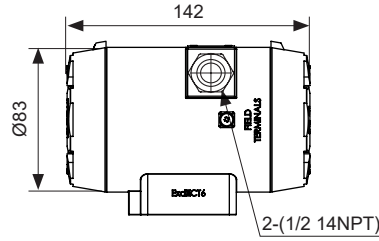
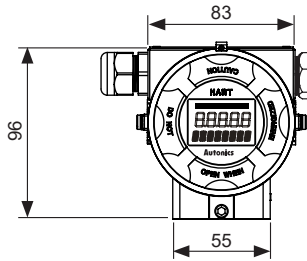

### ● Mounting bracket

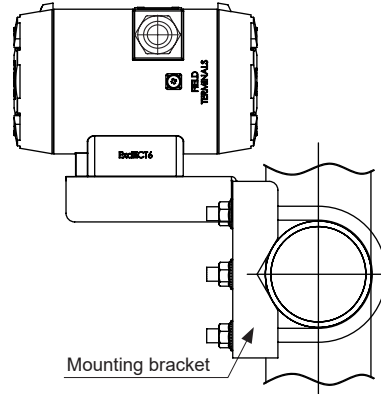
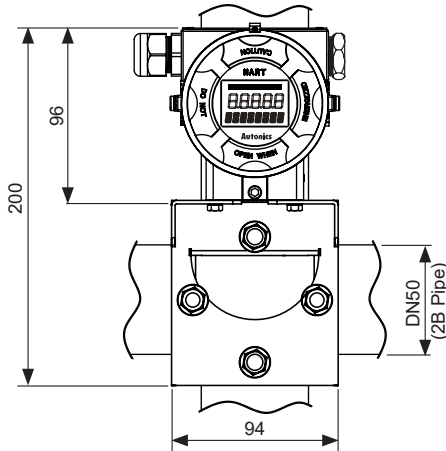

## ■ Input Type and Range

| Input type             |                  | Input range(°C) | Input range(°F) |
|------------------------|------------------|-----------------|-----------------|
| RTD                    | DPT100Ω          | -200 to 850     | -328 to 1562    |
|                        | DPT500Ω          | -200 to 250     | -328 to 482     |
|                        | DPT1000Ω         | -200 to 250     | -328 to 482     |
|                        | Cu50Ω            | -50 to 150      | -58 to 302      |
|                        | Cu100Ω           | -50 to 150      | -58 to 302      |
|                        | Ni100Ω           | -60 to 180      | -76 to 356      |
|                        | Ni500Ω           | -60 to 180      | -76 to 356      |
|                        | Ni1000Ω          | -60 to 150      | -76 to 302      |
| Resistance transmitter | Resistance (Ω)   | 0 to 400Ω       | —               |
|                        |                  | 0 to 2000Ω      | —               |
| Thermocouple           | B (PtRh30-PtRh6) | 0 to 1820       | 32 to 3308      |
|                        | E(NiCr-CuNi)     | -270 to 1000    | -454 to 1832    |
|                        | J(Fe-CuNi)       | -210 to 1200    | -346 to 2192    |
|                        | K(NiCr-Ni)       | -270 to 1372    | -454 to 2501.6  |
|                        | N(NiCrSi-NiSi)   | -270 to 1300    | -454 to 2372    |
|                        | R(PtRh13-Pt)     | -50 to 1768     | -58 to 3214.4   |
|                        | S(PtRh10-Pt)     | -50 to 1768     | -58 to 3214.4   |
|                        | T(Cu-CuNi)       | -270 to 400     | -454 to 752     |
| Analog                 | Voltage          | -10 - 75mV      | —               |
|                        |                  | -100 - 100mV    | —               |
|                        |                  | -100 - 500mV    | —               |
|                        |                  | -100 - 2000mV   | —               |

## ■ Connections

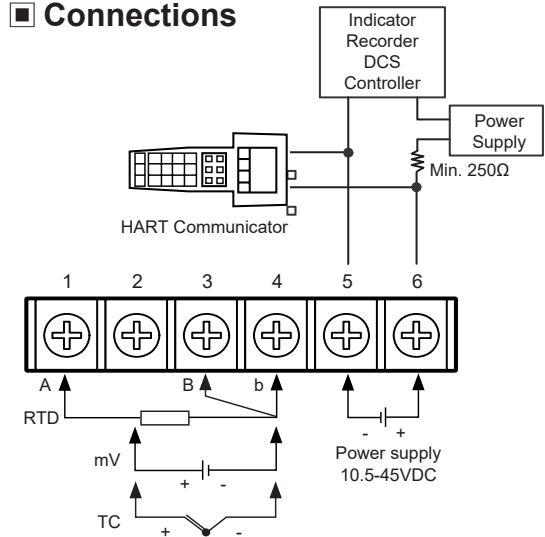

### ● Opening cover

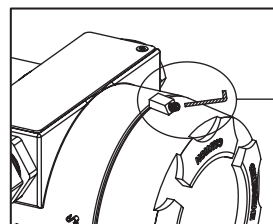

To open the cover, unscrew the M3×6L headless bolt using a 1.5 hexagon wrench and rotate the cover.

# KT-502H Series

## ■ Current Trim Adjustment

Connect a HART communicator and adjust current trim as below by a HART communicator.

- ① Select the '**1. Device Setup**' by  $\uparrow$ ,  $\downarrow$  keys and press the  $\rightarrow$  key.

1. Device Setup  
2. PV  
3. PV Ao  
4. PV LRV  
5. URV

- ② Select the '**2. Diag/Service**' by  $\uparrow$ ,  $\downarrow$  keys and press the  $\rightarrow$  key.

1. Process Variables  
2. Diag/Service  
3. Basic Setup  
4. Detailed Setup  
5. Review

- ③ Select the '**4. D/A trim**' by  $\uparrow$ ,  $\downarrow$  keys and press the  $\rightarrow$  key.

1. Test device  
2. Loop test  
3. Calibration  
4. D/A trim

- ④ Press the **OK** (F4) key.

WARN-Loop should be removed from automatic control

**ABORT** **OK**

- ⑤ Press the **OK** (F4) key.

Connect reference meter

**ABORT** **OK**

- ⑥ Press the **OK** (F4) key.

Setting fid dev output to 4mA

**ABORT** **OK**

- ⑦ Press the **ENTER** (F4) key to set 4 mA display value.

Enter meter Value  
4.000

**HELP** **DEL** **ABORT** **ENTER**

- ⑧ If output display value is correct, select '**1. Yes**' and press the **ENTER** (F4) key. If not, select '**2. No**' and press the **ENTER** (F4) key and re-set the display value.

- Ex) If output display value is 3.89mA, select 3.89 and press the **ENTER** (F4) key.

Fid dev output 4.000 mA equal to reference meter ?  
1. Yes

2. No **ABORT** **ENTER**

- ⑨ Press the **OK** (F4) key.

Setting fid dev. output to 20mA

**ABORT** **OK**

- ⑩ Press the **ENTER** (F4) key to set 20 mA display value.

Enter meter Value  
20.000

**HELP** **DEL** **ABORT** **ENTER**

- ⑪ If output display value is correct, select '**1. Yes**' and press the **ENTER** (F4) key. If not, select '**2. No**' and press the **ENTER** (F4) key and re-set the display value.

Fid dev output 20.000 mA equal to reference meter ?

1. Yes

2. No **ABORT** **ENTER**

- ⑫ Press the **OK** (F4) key.

NOTE-Loop may be returned to automatic control

**ABORT** **OK**

- ⑬ Press the **HOME** (F3) key.

Diag/Service

1. Test device  
2. Loop test  
3. Calibration  
4. D/A trim

**HELP** **SAVE** **HOME**

- ⑭ Press the **QUIT** (F3) key.

Device Disconnected

**RETRY** **QUIT**

- ⑮ Press the  $\boxtimes$  (F3) key to complete the adjustment.

1. Offline  
2. Online  
3. Frequency Device  
4. Utility

## ■ Error Display and Troubleshootings

| Display | Error   | Troubleshooting                                      |
|---------|---|--|
| Err05   | Temperature sensor A, B or all sensors are disconnected.              | Check the temperature sensor.                        |
| Err06   | Temperature sensor B is disconnected.                                 |  |
| Err07   | When PV is lower than the low-limit value of set temperature range.   | Check low-limit value of the set temperature range.  |
| Err08   | When PV is higher than the high-limit value of set temperature range. | Check high-limit value of the set temperature range. |

# Temperature Transmitters with HART Protocol

## ■ Temperature Range Setting

Connect a HART communicator and set temperature range as below by a HART communicator.

- ① Press the **↵** key for 3 sec. Select the '4. PV LRV' by **↑**, **↓** keys and press the **→** key.

|                  |      |
|------------------|------|
| Online (Generic) |      |
| 1. Device Setup  |      |
| 2. PV            |      |
| 3. PV Ao         |      |
| 4. PV LRV        |      |
| 5. URV           | SAVE |

- ② Select '1. PV LRV'(Low temperature range) and press the **→** key.

|           |      |
|-----------|------|
| 1. PV LRV |      |
| 2. URV    |      |
| HELP      | HOME |

- ③ Set Low temperature range and press the **ENTER** (F4) key.

|             |     |     |       |
|-------------|-----|-----|-------|
| PV LRV      |     |     |       |
| 0.000 deg C |     |     |       |
| 0.000       |     |     |       |
| HELP        | DEL | ESC | ENTER |

- ④ Select '2. URV'(High temperature range) and press the **→** key.

|           |      |
|-----------|------|
| 1. PV LRV |      |
| 2. URV    |      |
| HELP      | HOME |

- ⑤ Set High temperature range and press the **ENTER** (F4) key.

|               |     |     |       |
|---------------|-----|-----|-------|
| PV URV        |     |     |       |
| 100.000 deg C |     |     |       |
| 100.000       |     |     |       |
| HELP          | DEL | ESC | ENTER |

- ⑥ When the set temperature range is correct, press the **SEND** (F2) key.

|                       |      |      |
|-----------------------|------|------|
| 1. PV LRV 0.000 deg C |      |      |
| 2. URV 100.000 deg C  |      |      |
| HELP                  | SEND | HOME |

- ⑦ Press the **OK** (F4) key.

|                      |  |
|----------------------|--|
| - WARNING -          |  |
| Pressing 'OK' will   |  |
| change device output |  |
| put 100P in manual   |  |

- ⑧ Press the **OK** (F4) key.

|                      |  |
|----------------------|--|
| - WARNING -          |  |
| Return control 100P  |  |
| To automatic control |  |
| OK                   |  |

- ⑨ Check the set temperature range. Press the **HOME** (F3) key. HART communication is OFF.

|                       |      |
|-----------------------|------|
| 1. PV LRV 0.000 deg C |      |
| 2. URV 100.000 deg C  |      |
| HELP                  | HOME |

## ■ Proper Usage

### ◎ Cautions During Use

- Follow instructions in 'Cautions during Use'. Otherwise, it may cause unexpected accidents.
  - Power supply should be insulated and limited voltage/current or Class 2, SELV power supply device.
  - Keep away from high voltage lines or power lines to prevent inductive noise. Do not use near the equipment which generates strong magnetic force or high frequency noise.
  - Install a power switch or circuit breaker in the easily accessible place for supplying or disconnecting the power.
  - The explosion-proof standard of this unit is Ex d IIC T6, protection structure of this unit is IP67 and the range of max. surface temperature is below 85 °C. Use the verified explosion-proof electric connection (cable gland or sealing fitting)
  - This unit may be used in the following environments.
    - ① Indoors (in the environment condition rated in 'Specifications')
    - ② Altitude max. 2,000m
    - ③ Pollution degree 2
    - ④ installation Category II
- ※ The explosion-proof unit is certified and the same specifications which is reported to Korea Gas Safety Corporation. (This unit is manufactured following by the announcement 2013-54 of Ministry of Employment and Labor of Korea.)